



ELS-1100 Series Electro-Optic Level Switch

Specifications

Materials	
Housing and Prism	Polysulfone or Nylon
Operating Pressure	0 to 150 psig, Max.
Operating Temperature	0°F to 176°F (-17.8°C to +80°C)
Current Consumption	18 mA, Approximately
Input Voltage	See Part Number Chart
Output	TTL/CMOS Compatible, Open Collector Output may Sink 40 mA up to 30 VDC
Repeatability	±1 mm
EMI Susceptability	Meets Specification (MIL-STD-461B Part 2 Modified) of 10 V/M for Frequency Range 30 to 1000 MHz (Except 609 MHz = 9 V/M and 679 MHz = 7.5 V/M)
Approvals	C.E. EN 61326 Units Labeled UL. File E 108913

Note: Not for use in freezing liquids

Installation

1. For NPT threaded units:
 - a. Use Teflon (TFE) thread tape or Permatex #80725 plastic pipe sealant to seal thread. **Caution: Pipe sealant must not come in contact with prism surface.**
 - b. Thread sensor into tank wall and tighten by hand. Further tighten an additional one to two threads past hand-tightness. **(Avoid overtightening, as this may damage threads.)**
2. For 1/2" and M12 straight threaded units:
 - a. Thread sensor into tank wall by hand until sensor housing contacts tank wall surface. (See below for mating o-ring gland design information.)
 - b. The sensor shall be torque tightened to 12 to 24 in-lb (1.4 to 2.7 N-m). This range is slightly more than "hand-tight" to insure sealing, and less than that which would cause housing or thread damage.
 - c. **CAUTION:** Under no circumstances shall the sensor be tightened more than 1/6 turn beyond that required to seat the bottom of the sensor housing with the outside wall of the tank.
3. Sensor may be installed in **horizontal or vertical** position only.
4. **Caution:** Do not install sensor close to infrared sources or incandescent light. **(Note: Any optical sensor may be affected by reflective surfaces. Consult Gems if prism is to be less than 2 inches from any reflective surface.)**

The test depicted below was performed to determine the sensor immunity level to ambient light. The recorded ambient is the maximum level at which the sensor performs/detects normally.

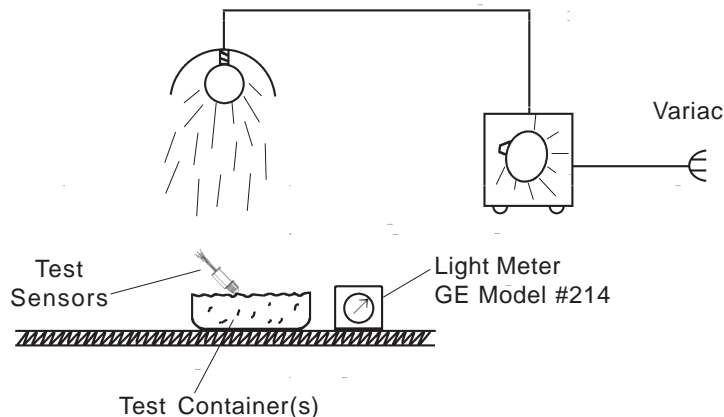

Input Power	Part Number	Probe Condition At Current Sink
5 VDC	138167	Wet
	144225	Wet
	144235	Wet
	166541	Wet
	175631	Wet
	187575	Wet
	187590	Dry
10-28 VDC	142700	Wet
	143570	Dry
	143575	Dry
	143577	Wet
	143580	Wet
	143585	Wet
	143590	Dry
	148973	Dry
	157750	Wet
	169555	Wet
	169556	Dry
	175632	Dry
	187580	Dry
	187585	Wet

Sensor Type	Black Container	Opaque Container
ELS-1100 Polysulfone	300 Ft-Cd	45 Ft-Cd
ELS-1100 TFE	100 Ft-Cd	25 Ft-Cd
ELS-1100HT Isoplast	500 Ft-Cd	250 Ft-Cd
ELS-1200 RE	250 Ft-Cd	25 Ft-Cd
ELS-1200	>1000 Ft-Cd	700 Ft-Cd
ELS-1200CR	400 Ft-Cd	25 Ft-Cd
ELS-1100 Nylon	65 Ft-Cd	25 Ft-Cd

Note: 1 Ft-Cd = 10.7 Lux

Above testing is based on minimum readings of at least two (2) samples.

Installation (Contd.)

- Connect VDC ($\pm 10\%$) power to red lead; return (-) to black lead. **Caution: Do not connect output to VDC power without a load.**
- Output Configuration: See Wiring Diagrams.

Maintenance

Sensor may require a periodic cleaning of prism surface.
Chlorinated hydrocarbons must not be used for cleaning.
 A mild detergent may be used to clean prism surface.

Return Policy

Returns are accepted on stock items up to 30 days from date of order. You must contact our Returns Department for a Return Authorization (RA) number. Return the goods - freight prepaid - in the original container and include original packing slip.
 C. O. D. returns are not accepted. Gems reserves the right to apply restocking charges.

Tel: 860-793-4357
 Fax: 860-793-4563

Typical Wiring Diagrams

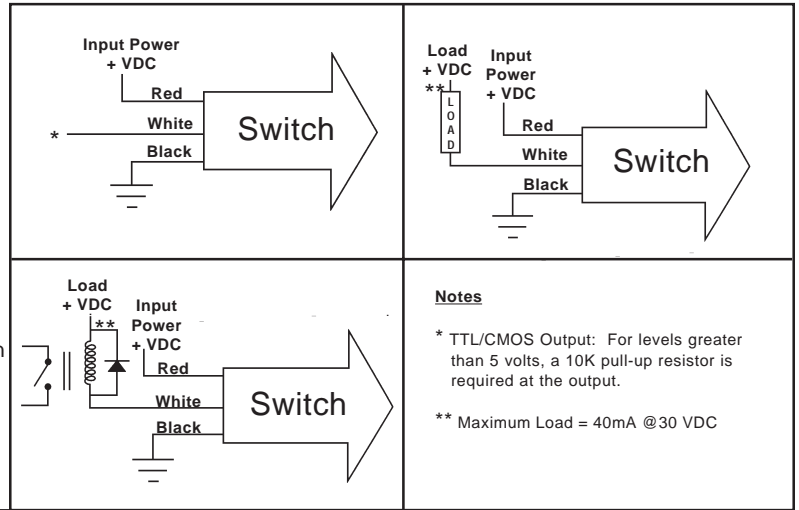

Mating O-Ring Gland Design

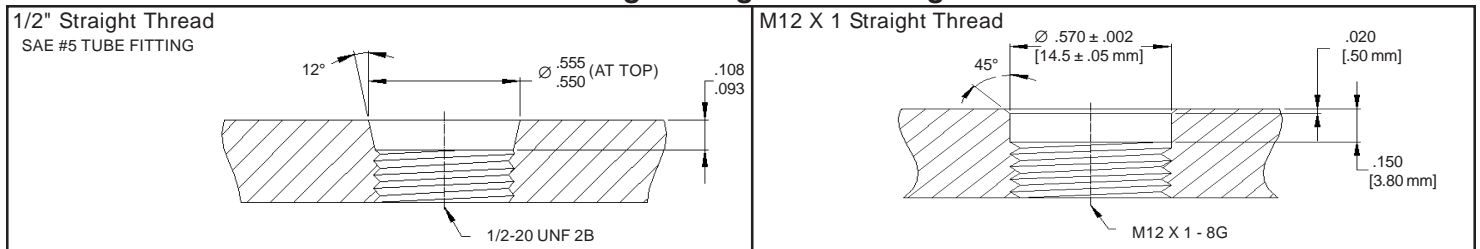

Dimensions

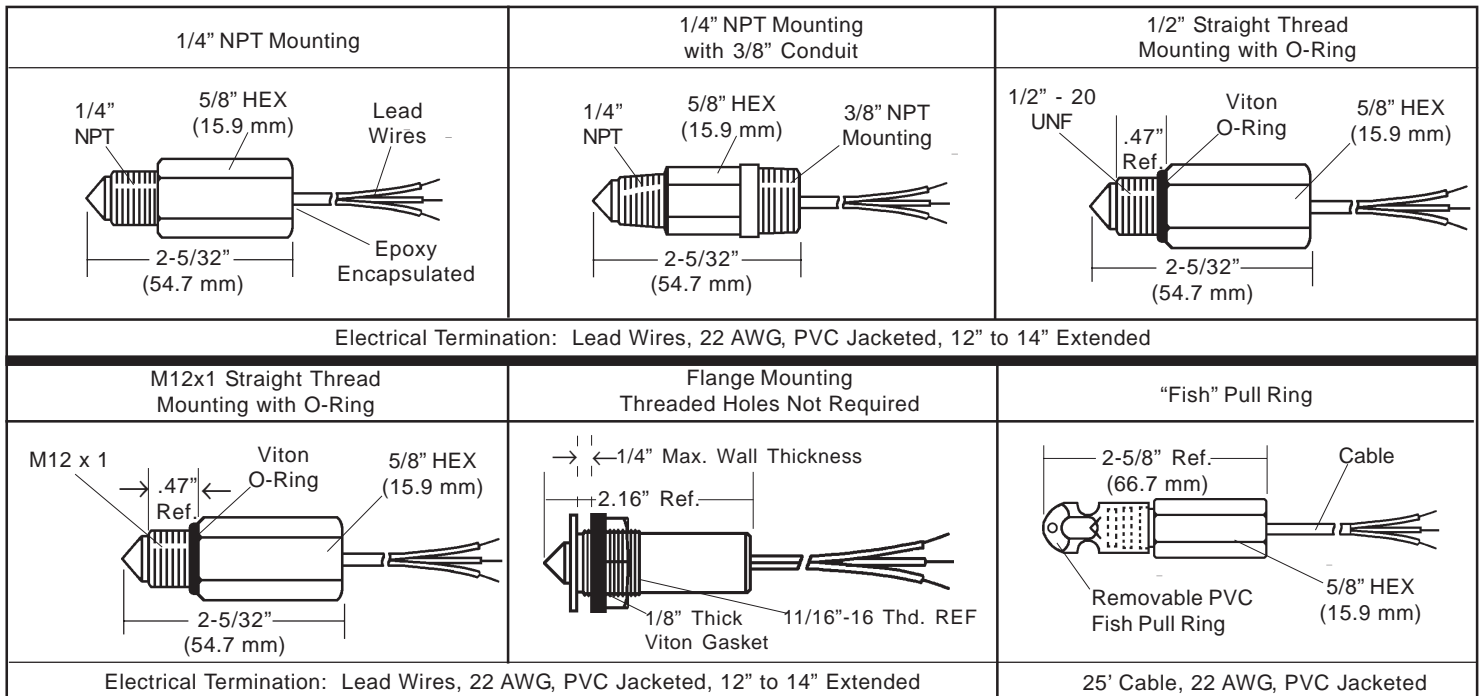

Important Points:

- Gems products must be maintained and installed in strict accordance with the National Electrical Code and the applicable Gems Product Instruction Bulletin that covers installation, operation and proper maintenance. Failure to observe this information may result in serious injury or damages.
- For hazardous area applications involving such things as, but not limited to, ignitable mixtures, combustible dust and flammable materials, use an appropriate explosion proof enclosure or intrinsically safe interface device.
- Please adhere to the pressure and temperature limitations shown throughout this catalog for our level and flow sensors. These limitations must not be exceeded. These pressures and temperatures take into consideration possible system surge pressures, temperatures and their frequencies.
- Selection of materials for compatibility with the media is critical to the life and operation of Gems products. Take care in the proper selection of materials of construction, testing is required.
- Stainless steel is generally regarded as safe by NSF and FDA.
- NSF-approved sensors are made of materials approved for potable water applications according to Standard 61.
- Life expectancy of switch contacts varies with application. Contact Gems if life cycle testing is required.
- Ambient temperature changes do affect switch set points, since the gravity of a liquid can vary with temperature.
- Our sensors have been designed to resist shock and vibration. However, shock and vibration should be minimized.
- Filter liquid media containing particulate and/or debris to ensure the proper operation of our products.
- Electrical entries and mounting points in an enclosed tank may require liquid/vaporsealing.
- Our sensors must not be field-repaired.



Gems Sensors Inc.
 One Cowles Road
 Plainville, CT 06062-1198
 Toll-Free: 1-800-378-1600